

**Readington Township**



**Hunterdon County**

**REQUEST FOR BIDS**

**FIRST RESPONSE VEHICLE**

**Bid Receipt Date – November 22, 2024**

**Time – 11:00 AM**

**PUBLIC NOTICE  
READINGTON TOWNSHIP  
NOTICE OF BID**

**PLEASE TAKE NOTICE** that Readington Township is accepting bids for the acquisition of the following automotive equipment to the Readington Township First Aid & Rescue Squad (Whitehouse Rescue).:

**FIRST RESPONSE VEHICLE**

A copy of the bid document may be obtained at the office of the Township Administrator, 509 Route 523, Whitehouse Station, NJ 08889 or via email at [admin\\_aj@readingtontwp-nj.org](mailto:admin_aj@readingtontwp-nj.org). All bids must be submitted to Richard J. Sheola, Township Administrator, 509 Route 523, Whitehouse Station, NJ 08889 by November 22, 2024 – 11:00 AM.

**CHECK LIST OF REQUIRED DOCUMENTS**

The following items are required submissions in this bid package:

	<b>Initials</b>
Affirmative Action Requirements	✓ _____
Americans With Disabilities Act	✓ _____
Applicant and Sub-Applicant Business Registration Certificate	✓ _____
Corporate Disclosure Statement	✓ _____
Qualification Bid Form	✓ _____
Acknowledgment of Addenda (as applicable)	✓ _____
Affidavit of Non-Collusion	✓ _____
Readington Township Professional Appointment Certification	✓ _____
Readington Township Dispute Resolution Acknowledgement	✓ _____
Checklist of Required Documents, signed below	✓ _____

EACH REQUIRED ITEM MUST BE INITIALED ON THIS FORM IN THE SPACE PROVIDED.  
 THIS CHECKLIST MUST BE SIGNED AND SUBMITTED WITH THE BID PACKAGE.

\_\_\_\_\_  
 COMPANY / APPLICANT'S NAME

\_\_\_\_\_  
 AUTHORIZED SIGNATURE

\_\_\_\_\_  
 DATE

\_\_\_\_\_  
 NAME (PRINT) TITLE

READINGTON TOWNSHIP  
REQUEST FOR BIDS: UTILITY/RESPONSE VEHICLE FOR WHITEHOUSE RESCUE  
BID RECEIPT DATE: NOVEMBER 22, 2024- 11:00 AM

---

The undersigned declares that he/she has carefully examined and fully the Bid Specifications and other documents herein referred to and agrees to furnish and deliver all materials and to perform all work in accordance with the contract documents for the acquisition of a First Response/Utility Vehicle.

\_\_\_\_\_  
Applicant's Name

\_\_\_\_\_  
Authorized Signature

\_\_\_\_\_  
Print Name

\_\_\_\_\_  
Title

\_\_\_\_\_  
Telephone

\_\_\_\_\_  
Fax

\_\_\_\_\_  
E-Mail Address

**Witness or Attest:**

\_\_\_\_\_  
Signature

\_\_\_\_\_  
Print Name  
(If Corporation, affix Corporate Seal)

**GENERAL INFORMATION FOR BIDDERS**

**I. SUBMISSION OF QUALIFICATIONS**

- A. Readington Township, Hunterdon County, New Jersey (hereinafter referred to as "TOWNSHIP") invites sealed bids pursuant to the Notice to Bidders.
- B. Sealed bids will be received by the designated representative at the time and place stated in the Notice to Bidders, and at such time and place will be publicly opened and read aloud.
- C. The bid form shall be submitted, in a sealed envelope: (1) addressed to the TOWNSHIP, (2) bearing the name and address of the applicant written on the face of the envelope, and (3) clearly marked "RESPONSE VEHICLE".
- D. It is the applicant's responsibility to see that bids are presented to the TOWNSHIP on the hour and at the place designated. Bids may be hand delivered or mailed; however, the TOWNSHIP disclaims any responsibility for bids forwarded by regular or overnight mail. If the bid is sent by overnight mail, the designation in section C, above, must also appear on the outside of the delivery company envelope. Bids received after the designated time and date will be returned unopened.
- E. Sealed bids forwarded to the TOWNSHIP before the time of Receipt of bids may be withdrawn upon written application of the applicant who shall be required to produce evidence showing that the individual is or represents the principal or principals involved in the bid. Once bids have been opened, they must remain firm for a period of sixty (60) calendar days.
- F. All prices and amounts must be written in ink or preferably typewritten. Bids containing any conditions, omissions, unexplained erasures or alterations, items not called for in the bid form, attachment of additive information not required by the specifications, or the TOWNSHIP may reject irregularities of any kind. Any changes, whiteouts, strikeouts, etc. on the bid page must be initialed in ink by the person responsible for signing the bid.
- G. Each bid form must give the full business address of the applicant and be signed by an authorized representative. Bids by partnerships must furnish the full name of all partners and must be signed in the partnership name by one of the members of the partnership or by an authorized representative, followed by the signature and designation of the person signing. Bids by corporations must be signed in the legal name of the corporation, followed by the name of the State in which incorporated and must contain the signature and designation of the president, secretary or other person authorized to bind the corporation in the matter. When requested, satisfactory evidence of the authority of the officer signing shall be furnished.

## **II. INTERPRETATION AND ADDENDA**

A. The applicant understands and agrees that its bid is submitted on the basis of the requirements prepared by the TOWNSHIP. The applicant accepts the obligation to become familiar with these requirements.

B. Bidders are expected to examine the requirements with care and observe all their requirements. Ambiguities, errors or omissions noted by bidders should be promptly reported in writing to the appropriate official. In the event the applicant fails to notify the TOWNSHIP of such ambiguities, errors or omissions, the applicant shall be bound by the bid.

C. No oral interpretation of the meaning of the specifications will be made to any applicant. Every request for an interpretation shall be in writing, addressed to the TOWNSHIP'S representative stipulated in the bid. In order to be given consideration, written requests for interpretation must be received at least five (5) days prior to the date fixed for the Receipt of the bids. Any and all such interpretations and any supplemental instructions will be in the form of written addenda to the specifications, and will be distributed to all prospective bidders, in accordance with N.J.S.A. 40A:11-23. All addenda so issued shall become part of the contract documents and shall be acknowledged by the applicant in the bid. The TOWNSHIP'S interpretations or corrections thereof shall be final.

## **III. PREPARATION OF BIDS**

A. The Township is exempt from any local, state or federal sales, use or excise tax.

## **IV. STATUTORY AND OTHER REQUIREMENTS**

### **A. Mandatory Affirmative Action Certification**

No firm may be issued a contract unless it complies with the affirmative action regulations of N.J.S.A. 10:5-31 et seq. (P.L.1975, c.127).

#### **1. Procurement, Professional and Service Contracts**

All successful vendors must submit, within seven days after the receipt of the notice of intent to award the contract or the receipt of the contract, one of the following:

i. A photocopy of a valid letter for an approved Federal Affirmative Action Plan (good for one year from the date of the letter), or

ii. A photocopy of an approved Certificate of Employee Information Report, or

iii. If the vendor has none of the above, the public agency is required to provide the vendor with an initial Affirmative Action Employee Information Report (AA-302).

B. Americans with Disabilities Act of 1990

Discrimination on the basis of disability in contracting for the purchase of bids and services is prohibited. The successful applicant is required to read Americans with Disabilities language that is part of this specification and agrees that the provisions of Title II of the Act are made a part of the contract. The successful applicant is obligated to comply with the Act and to hold the TOWNSHIP harmless.

C. Stockholder Disclosure

Chapter 33 of the Public Laws of 1977 provides that no corporation or partnership shall be awarded any contract for the performance of any work or the furnishing of any materials or supplies, unless, prior to the receipt of the bid or accompanying the bid of said corporation or partnership, there is submitted a statement setting forth the names and addresses of all stockholders in the corporation or partnership who own ten percent or more of its stock of any class, or of all individual partners in the partnership who own a ten percent or greater interest therein. Form of Statement shall be completed and attached to the bid.

D. Non-Collusion Affidavit

The Non-Collusion Affidavit, which is part of these specifications, shall be properly executed and submitted with the bid.

E. New Jersey Business Registration Requirements

Non-Construction Contracts – The Contractor shall provide written notice to its subcontractors of the responsibility to submit proof of business registration to the contractor.

Before final payment on the contract is made by the contracting agency, the Contractor shall submit an accurate list and the proof of business registration of each subcontractor or supplier used in the fulfillment of the contract, or shall attest that no subcontractors were used.

For the term of the contract, the contractor and each of its affiliates and a subcontractor and each of its affiliates (N.J.S.A. 52:32-44 (g) (3) shall collect and remit to the Director, New Jersey Division of Taxation, the use tax due pursuant to the Sales and use Tax Act on all sales of tangible personal property delivered into this State, regardless of whether the tangible property is intended for a contract with a contracting agency.

A business organization that fails to provide a copy of a business registration as required pursuant to Section 1 of P.L. 2001, c134 (C.52:32-44 et al) or subsection e. or f. of section 92 of P.L. 1977, c.110 (C.5:12-92), or that provides false business registration information under the requirements of either of those sections, shall be liable for a penalty of \$25 for each day of violation, not to exceed \$50,000 for each business registration copy not properly provided under a contract with a contracting agency.

**Failure to submit this shall be cause for rejection of the bid.**

## **V. METHODS OF AWARD**

The contract will be awarded to the lowest price from the most responsible and responsive bidder.

## **VI. TERMINATION OF CONTRACT**

A. If, through any cause, the successful applicant shall fail to fulfill in a timely and proper manner obligations under this contract or if the contractor shall violate any of the requirements of this contract, the TOWNSHIP shall thereupon have the right to terminate this contract by giving written notice to the contractor of such termination and specifying the effective date of termination. Such termination shall relieve the TOWNSHIP of any obligation for balances to the contractor of any sum or sums set forth in the contract.

B. Notwithstanding the above, the contractor shall not be relieved of liability to the TOWNSHIP for damages sustained by the TOWNSHIP by virtue of any breach of the contract by the contractor and the TOWNSHIP may withhold any payments to the contractor for the purpose of compensation until such time as the exact amount of the damage due the TOWNSHIP from the contractor is determined.

C. The contractor agrees to indemnify and hold the TOWNSHIP harmless from any liability to subcontractors/suppliers concerning payment for work performed or goods supplied arising out of the lawful termination of the contract by the TOWNSHIP under this provision.

D. In case of default by the successful applicant, the TOWNSHIP may procure the articles or services from other sources and hold the successful applicant responsible for any excess cost occasioned thereby.



**EXHIBIT A**

**BID NOTICE FOR ONE (1) RESPONSE VEHICLE**

1. The Readington Township is seeking sealed bids for providing a RESPONSE VEHICLE as the per enclosed specifications.
2. All sealed bids shall be submitted to Richard J. Sheola, Township Administrator, 509 Route 523, Whitehouse Station, NJ 08889 by November 22, 2024 – 11:00 AM.
3. All bids shall include, at a minimum: the name, address and all contact information of the person or firm making the bid; a statement of qualifications; a statement of experience in rendering such services to public entities; and a bid for the vehicle.
4. All bids will be evaluated by Whitehouse Rescue, the Township Administrator of Readington Township with legal review by the Township Attorney.
5. Contract will be awarded by the Township Committee of Readington Township on the basis of the bids deemed to be most advantageous, price and other factors considered. The evaluation will consider:
  - a. Experience and reputation in the field;
  - b. Delivery schedule;
  - c. Price
  - d. Any and all exceptions to the bid specifications.

## **BID SPECIFICATIONS**

### **Chassis**

One (1) 2024 or newer model year Chevy Tahoe SSV. Please see the attachment for options included in the vehicle.

### **CHASSIS WARRANTY**

One (1) Premium Care extended warranty of 7 years / 125,000 miles with \$100 deductible shall be provided. It should be noted that the warranty provided shall explicitly recognize that the warranty is to cover an Emergency Vehicle used for Whitehouse Rescue Squad. A standard warranty for consumer vehicles will NOT be accepted. No Exceptions.

### **CUSTOM ELECTRICAL WIRING HARNESS**

This conversion shall have a custom wiring harness throughout the vehicle. The harness shall integrate with the OEM factory plugs and connectors to avoid any splicing and cutting into the factory wiring harness. All wiring shall be GXL wire and function coded every 4" utilizing a minimum of 10 different colors and protected with high temperature loom. As industry standard, there will be no slices or connectors within any harness. The wiring shall have a snap ring grommet included where it passes through a wall.

### **CAB DOME LIGHT**

One (1) Whelen 6" model #60CREGCS, wired ignition hot. Mounted in the front cab between the driver and passenger.

### **FRONT LIGHT BAR**

Install a Whelen Legacy fully populated DUO light bar. Adjustable lightbar mount shall be included with installation. Shall include black mounting kit (MDAJ101) and midnight edition lenses (ES2ME).

### **FRONT PUSH BUMPER:**

One (1) Westin Push Bumper Elite with Pit Bar Elite, Wing Wrap Elite, 33.1 4 head light channel with wire covers shall be mounted to the front of the vehicle.

### **FRONT WARNING:**

Four (4) Whelen DUO smoked IONS shall be mounted in the grille area and four (4) additional Whelen DUO smoked ION shall be mounted in the wing wrap Pit area.

### **FLOOD LIGHT:**

One Whelen Summit 30" with R/B warning and marker lights shall be installed on the center of the front push bumper. The summit shall have two (2) 15' cables with flat low rising mounting kit.

**HEADLIGHT FLASHER:**

A Whelen UHF2150A flasher circuit model shall be connected to the vehicle's high beam circuit for wig-wag pattern.

**SIDE RUNNING BOARD WARNING**

Two (2) Whelen WeCanX Tracer 6 lamp light head. TRIO Color LED – Red/Blue/White. (One per side)

**SIDE WARNING**

One (1) Whelen TLI2DX, ION T-series DUO RW Smoked and One (1) TLI2EX, Whelen ION T series DUO BW smoked shall be mounted on the side of the push bumper to provide intersection warning.

One (1) Whelen PSLC3FCR, Mega T Series TRIO flasher R/G/W and One (1) Whelen PSNC3FCR, Mega T series TRIO flasher B/G/W shall be installed in the side cargo windows.

**TAIL LIGHT / REVERSE LIGHTS**

One Whelen SSF5150D, back flasher that will alternate with the brake lights and reverse lights.

**REAR TAILGATE WARNING**

Two (2) Whelen IONS shall be mounted under the rear tailgate. The shall be TRIO color with Red/Amber/Green on the driver's side and Blue/ Amber/Green on the passenger side.

**TRAFFIC ARROW**

One (1) Whelen ION Outer edge WC DUO shall be mounted on the rear hatch above the rear window. The outer edge shall be red/amber on the driver's side and blue-amber on the passenger side.

**REAR WARNING**

Two (2) Whelen ION T Series shall be mounted and installed near the rear license plate on the rear hatch. The colors shall be Red/Blue/White. The white shall

automatically turn on when the vehicle is placed into reverse. It shall also activate when the rear scene or full scene lights are activated.

### **SIREN AND LIGHT CONTROLLER**

One (1) Whelen CORE WeCanX control center. Includes: OBDII canport Tahoe kit, control head CCTL6, vehicle to vehicle sync module, four (4) WeCanX 16 output expansion modules, one (1) 4 output high capacity expansion module, WeCan external amplifier (2 siren tones at the same time, if desired).

Two (2) Whelen SA315P 100 watt siren speakers with siren brackets.

One (1) Whelen Howler low frequency siren. Whelen Howler™ **Low Frequency Siren & Speaker System** Product Description Adding a layer of warning for intersections and high risk areas when used with 100/200 watt siren amplifier, Howler provides deep tones to penetrate other vehicles, alerting drivers and pedestrians of approach.

### **SPOTLIGHT**

One (1) Whelen Arges Profocus Remote Spotlight will be mounted on the driver's side and passenger side fenders. A Whelen Arges control head will be mounted in the front center console and wired to the spotlights.

### **CONSOLE**

Havis wide body metal console. 12.5 Wide medium hight angled 22" Vehicle Specific console for a 2024 Chevy Tahoe. Console includes self adjusting dual cup holder, equipment brackets, filler brackets, 3-single lighter plugs, single usb, two side mount arm rests for the driver and passenger, 3 microphone 90 degree brackets and 3 magnetic microphone clips (two for the front radios and one for the PA microphone). 12" accessory pocket, 5.8D and 3.3W.

### **COMPUTER PEDESTAL & DOCK**

One (1) Heavy Duty Havis Dash mount for 2023 Tahoe. Havis part ##C-DMM-3019. Includes docking station (charge only) and tablet case for iPad 7<sup>th</sup> and 8<sup>th</sup> generation tablets. PKG-TAB-APP-6, C-HDM-307 (swivel arm mounts), MD-ARM-0606 swivel arm 6" base, C-MD-207 (tilt swivel device for tablet).

### **CUSTOM COMMAND CABINET**

One (1) Rockland incident command cabinet. (See attached drawing). Install three (3) radio head units, gear compartment, two (2) extinguishers will be installed behind cabinet,

install set of irons, install knox box, install streamlight charger and wire ignition hot. Customer to supply loose equipment and mounting brackets. See schematic at end of specifications.

#### **COMMAND CABINET LIGHTING:**

Three (3) 3" Red/white compartment lights shall be installed. One over the cabinet and two in the rear hatch. Lights shall be wired to an independent switch to cancel the lights and another switch to turn the lights red or white.

#### **GRAPHICS**

Provide and install a 3M Scotchlite vinyl graphics package for a Sport Utility Vehicle. A computer generated conceptual graphics plan including front, rear, left, right and top views of the layout will be presented for approval. Package includes the following (or equivalent):

- Door emblems: Two (2) door shield decals (approximately 18" high x 12" wide). One (1) installed on each front door, approximately one (1) inch behind the front door edge. Top edge just below the body side stripe
- Side Stripes: Five (5) inch 3M reflective tape stripe with one (1) inch of spacing above and below the stripe. One (1) inch 3M reflective stripe above and below the spacer of the Five (5) inch center stripe. Stripes shall run the full length of the vehicle's side, front to back.
- Rear Stripe: Five (5) inch 3M reflective tape stripe with one (1) inch of spacing above and below the stripe. One (1) inch 3M reflective stripe above and below the spacer of the Five (5) inch center stripe. Stripe shall run full width of vehicle's rear.
- Lettering: Two (2) sets of four (4) inch high vinyl letters stating the agency/ department's name. One (1) installed on each side of the vehicle
- One (1) set of four (4) inch high vinyl letters stating the Agency/ Department's name on the front edge of the hood.
- One set of four (4) inch high vinyl letters stating the Agency / Department's name on the rear hatch of the vehicle. Striping will match existing Whitehouse Rescue Squad existing fleet.

Since this vehicle is stored outside in the elements, the two (2) front windows shall be tinted to match the rear windows %. The tint shall be free from any bubbling and imperfections. Tint % will be 20%.

#### **COMMUNICATIONS EQUIPMENT**

##### **MOBILE RADIOS**

Vendor will supply and install the radios that are detailed in this spec below. Radios shall be programmed per Whitehouse Rescue Squad's specifications and shall include P25 Somerset County Code plug. All radios shall include ignition sense kits, microphones, and mounting brackets. Every mobile radio shall have a magnetic microphone clip installed at a location to be determined during final delivery.

HARRIS XL200M ALL-BAND MOBILE -DUAL HEAD

XZ-MPM1M MOBILE, XL-200M, MULTIBAND 1

XZ-PL4L FEATURE, 7/800 MHZ BAND 1

XZ-PL4K FEATURE, UHF BAND 1

XZ-PL4J FEATURE, VHF BAND 1

FEATURE PACKAGE, P25 TRUNKING

Includes Status Message

XZ-PKGPT 1

XZ-PL4F FEATURE, PHASE 2 TDMA 1

XZ-CP6A CONTROL UNIT, XL-CH 2 1

XZ-MC6A MICROPHONE, XL, STANDARD MOBILE 2

KIT, MOUNTING XL-MOBILE UNIVERSAL

Front and Remote Mount

XZ-MA4A 1

BRACKET, MOUNTING, XL CONTROL HEAD

XZ-MA4C 1

XT-CA6B CABLE, XL-MOBILE, ETHERNET, 9M 1

XZ-CA6D CABLE, POWER, XL-CH 1

SPEAKER, EXTERNAL, MOBILE Requires an accessory cable

XZ-LS6A 2

XZ-CA6F CABLE, XL-MOBILE, SPEAKER ACCY 2

FINB-5F LOW PROF FIN PANEL MOUNT-5m FME 1

ASFC-155-U2-B1 FLEXI 155MHz/U2/780MHz COMPRSD ANT 1

CA-TP-FP TNC(M)-FME(M) ADAPTOR 1  
TRI-BAND DUAL HEAD MOBILE  
TP9800 TRI-BAND PORTABLE  
TP9855N0BC-T P25 4Key VHF/UHF/700-800MHz - Blk 1  
TPAS134 SFE Key - Multiband (ALL BANDS) 1  
SFE Key - P25 Trunking Services Phase 2  
Includes TPAS050, TPAS055,TPAS064,TPAS091 TPAS152 1  
TPA-AN-051 TP98 Multi Ant 136-870MHz 1 120.00 20% 96.00 96.00  
T03-00011-EAAA High-Capacity Li-Ion 3300mAh 1  
TPA-CA-201 TP8/TP9 Belt Clip 55mm 1  
T03-00012-AEAA TP9 Single Unit Charger 1  
TP3/TP9 Spkr Mic TSM4 3W IP68 E-button  
Fctn-button 3.5mm-Jack  
T03-00045-PCAA 1  
EVC-TA2 Rugged In-Vehicle Charger for Tait 1  
TM9400 VHF Dual Head  
Mobile, TM9400, 136-174M 50W, M-UHF,AlmTM9400B1DA 1 1  
T02-00026-1004 CABLE, INSTALL KIT, M-UHF, 30-50W 1  
TCH4: REMOTE CONTROL HEAD  
WITH SPEAKER  
T02-00065-2001 2  
TM93/94 Control Head Remote Body End Multi Head Terminated Bias  
T02-00081-AAAA 1

TM93/94 Control Head Interface (Power/Dual Head)

T02-00088-AAAA 1

T02-00062-3001 Dual Remote Head Kit, 60ft 1

T02-00005-AAAA TM Standard Microphone TDMA 2

TM Rugged External Speaker 15W for 30-50W Radio T02-00004-0207 2

T02-00026-2001 MOUNTING KIT, U-CRADLE 2

T02-00034-EAAA CABLE IGNITION SENSE 13FT 1

MNMO BASE 5.25m(17) COAX FME(f), Mini-UHF MNMOM-5MP 1

SAB-196 NMO-M6F ADAPTOR ASSEMBLY 1

AFNT-H5 ANT ELEMENT 1/4W NiTi BLK 149-159 1

TM9400 UHF Single Head Mobile, TM9400, 450-520M 40W, M-UHF, Alm  
TM9400H7DA 1 1

TMAS152 SFE Key - P25 Trunking Services Phase 2 1

T02-00026-1004 CABLE, INSTALL KIT, M-UHF, 30-50W 1

TCH4: REMOTE CONTROL HEAD WITH SPEAKER T02-00065-2001 1

T02-00061-2001: Remote Head Upgrade Kit 6m (20ft)

T02-00061-2001 1

T02-00005-AAAA TM Standard Microphone TDMA 1

TM Rugged External Speaker 15W for 30-50W Radio

T02-00004-0207 1

T02-00034-EAAA CABLE IGNITION SENSE 13FT 1

T02-00026-2001 MOUNTING KIT, U-CRADLE 1

LP450NMO Black NMO Low Profile, Unity, 450 - 470 MHz 1

MNMOM-5F MNMO BASE 5.25m(17) COAX FME(f) 1



CA-MP-FP Mini UHF, Male

Supply and install two (2) Apple 11" Ipad Air M2 Chip Wifi plus cellular in supplied Havis bracket/charger on front console for CAD integration.

**MOBILE RADIO INSTALLATION**

Installation of all mobile radios.

Provide and install five (5) magnetic microphone clips.

Provide and install three (3) Havis microphone clip 90 brackets.

All radios including portables specified above shall be installed.

**120 VOLT POWER:**

20 amp super auto-eject White receptacle mounted on the left rear side of the vehicle wired to eject when the key is in the "start" position.

Included is a junction box with circuit breaker protection and one multi outlet strip for equipment.

Audible Warning: Buzzer activated with ignition when shore line is attached.

Shoreline warning light, interior: Power on indicator mounted on the console or dash activated when power is applied to the shore line.

Battery charger/monitor: 45-amp taper charger/monitor wired into shore line to maintain all batteries while on shore line without over charging.

**INVERTER:**

One (1) Vanner LSC Series Lifesine wave ambulance power inverter with 12Vdc input and 1100W AC output shall be installed.

**MISC:**

One (1) 110 volt ceramic interior heater will be supplied and installed to run via inverter or when the vehicle is plugged in.

WeatherTech front and rear floor mats (black) shall be provided and delivered with the vehicle.

Vendor to supply and mount the following in vehicle, per customer setup meeting:

1. Two (2) Styker Lucas chargers
2. One (1) HeartStart FRX defibrillator with carry case and pads
3. Two (2) Meret EMS bags with modules M8101NB, M8101C-TB, M10123H-GR, M10123H-TB

4. One (1) 880051 LCSU 4 800 ml Complete Suction Unit
5. One (1) Pelican 9455 RALS remote area light

***Customer supplied equipment:*** must arrive complete, correct for the installation and in good working condition. The price quoted in this proposal does not include any parts, components or repair to existing equipment but labor only and work cannot commence until all parts are here and complete. Used equipment may be subject to additional charges and will carry no warranty except for workmanship of installation and wiring only up to that component. If there are any product failures during or after the installation the repair and all related expenses are to be the responsibility of the customer.

***Production time: Vehicle must be delivered within 180 days after the award of the bid. If the vehicle is not delivered there shall be a penalty clause of \$50 each calendar day that the vehicle is late.***

PHONE# - (631)391-6007

PART NUMBER:

FC-CTAH24-C-4335-P-WO1906

- A = ADJUSTABLE SHELF W/ 1" ALUMINUM ANGLE
- C = GRAY CARPET
- BC = BLACK CARPET
- BL = BLACK LAMINATE
- DPLS = DIAMOND PLATE LS

DRAWN BY: S.W.

- \* STANDARD FILE DRAWER = 22" DEEP
- \* STANDARD COMMAND BOARD = 22" DEEP

\*usable drawer space is smaller than drawer opening dimensions\*



VEHICLE:

2024 CHEVY TAHOE

DATE:

8/13/2024

REVISIONS

REV	DATE
5/4	8/20/2024
5/4	8/22/2024

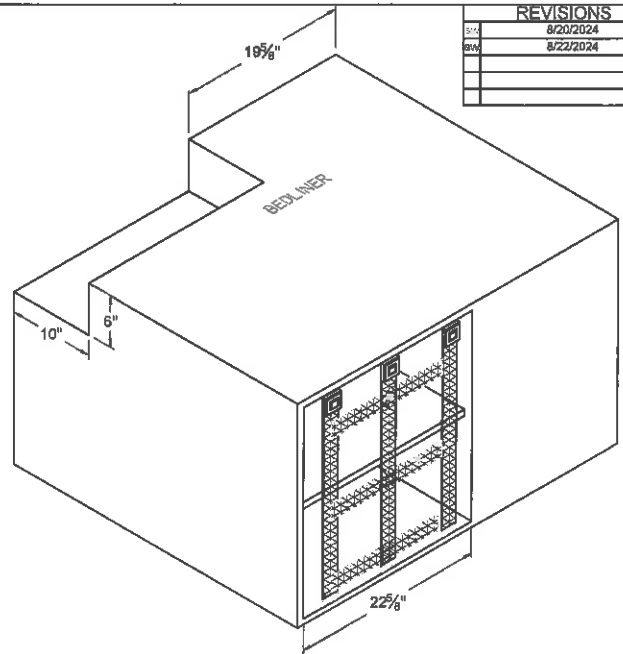
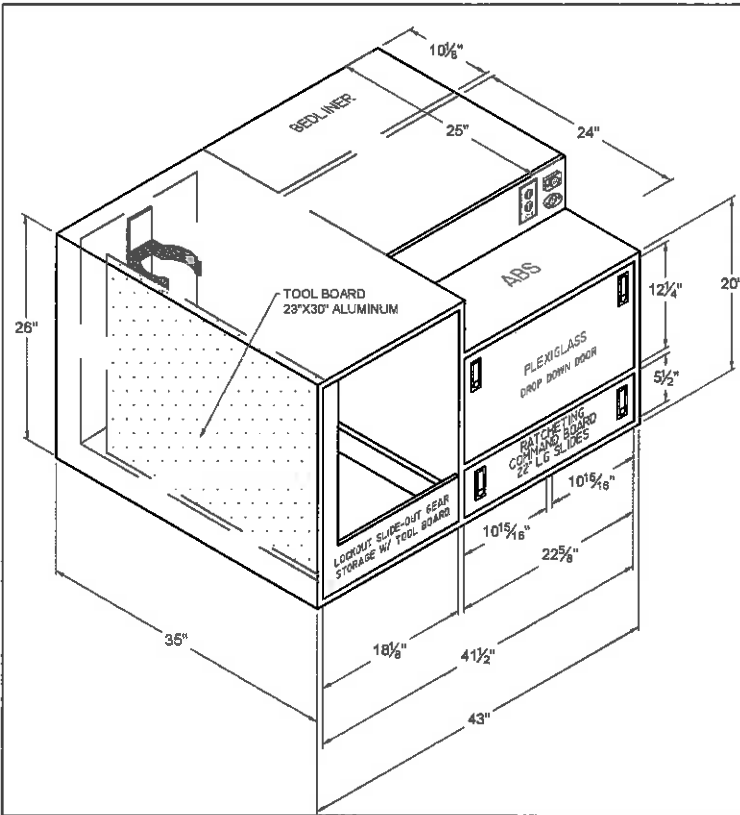

OVERALL CABINET DIMENSIONS MAY VARY (+/-) 1/4" BASED ON FINISHING MATERIALS AND COATINGS

WHAT SIZE SCBA BRACKET IS NEEDED? 30 MIN \_\_\_ 45 MIN \_\_\_ 60 MIN \_\_\_  
 SCBA BRACKET ONLY INCLUDED IF SHOWN OR NOTED  
 SCBA BRACKET INCLUDED WITH ALL GEARCLEAR.

BY APPROVING THESE CUSTOM PRODUCT SPECIFICATIONS YOU ACKNOWLEDGE THEM TO BE CORRECT, AUTHORIZE THE PRODUCTION OF THE UNIT(S), AND ASSUME ALL FINANCIAL RESPONSIBILITY FOR THIS ORDER

THIS DRAWING IS THE PROPERTY OF ROCKLAND CUSTOM PRODUCTS. IT IS NOT TO BE REPRODUCED OR DISCLOSED WITHOUT THE WRITTEN CONSENT OF ROCKLAND CUSTOM PRODUCTS.

SIGN: \_\_\_\_\_ APPROVED \_\_\_\_\_ DATE: \_\_\_\_\_ INITIALS: \_\_\_\_\_  
 ALL ORDERS ARE NON-CANCELLABLE ONCE RELEASED TO PRODUCTION

## VEHICLE SPECIFICATIONS

### Standard Equipment

#### Mechanical

Engine, 5.3L EcoTec3 V8 with Dynamic Fuel Management, Direct Injection and Variable Valve Timing, includes aluminum block construction (355 hp [265 kW] @ 5600 rpm, 383 lb-ft of torque [518 Nm] @ 4100 rpm) (STD)

Transmission, 10-speed automatic electronically controlled with overdrive, includes Traction Select System including tow/haul (STD)

Rear axle, 3.23 ratio

Suspension Package, Premium Smooth Ride (STD) GVWR, 7500 lbs. (3402 kg) (4WD models only.) (STD) Keyless start, push button

Automatic Stop/Start

Engine control, stop/start system disable button, non-latching Engine air filtration monitor

Fuel, gasoline, E15

Transfer case, active, single-speed, electronic Autotrac does not include neutral. Cannot be dinghy towed (4WD models only. Deleted when (NHT) Max Trailering Package is ordered.)

Differential, mechanical limited-slip 4-wheel drive

Air filter, heavy-duty

Cooling, external engine oil cooler, heavy-duty air-to-oil integral to driver side of radiator Cooling, auxiliary transmission oil cooler, heavy-duty air-to-oil

Battery, 730 cold-cranking amps with 80 amp hour rating Alternator, 220 amps

Trailering equipment includes trailering hitch platform, 7-wire harness with independent fused trailering circuits mated to a 7-way connector and 2" trailering receiver

Trailer sway control Hitch Guidance Suspension, front coil-over-shock with stabilizer bar Suspension, rear multi-link with coil springs Steering, power brakes, 4-wheel antilock, 4-wheel disc with DURALIFE rotors

Exhaust, single system, single-outlet

**Mechanical**

Mechanical Jack with tools

**Exterior**

Wheels, 18" x 8.5" (45.7 cm x 21.6 cm) Bright Silver painted aluminum (STD)

Tires, 265/65R18SL all-season, blackwall (Standard with (PZX) 18" Bright Silver painted aluminum wheels only.) (STD)

Wheel, full-size spare, 17" (43.2 cm)

Tire, spare P265/70R17 all-season, blackwall

Tire carrier, lockable outside spare, winch-type mounted under frame at rear Active aero shutters, upper fascia, front

Luggage rack side rails, roof-mounted, Black, standard (Available with (5W4) Special Services Vehicle.) Assist steps, Black with chrome accent strip

Headlamps, LED

Lamps, stop and tail, LED

Mirrors, outside heated power-adjustable, manual-folding, body-color Mirror caps, body-color

Glass, deep-tinted (all windows, except light-tinted glass on windshield and driver and front passenger-side glass)

Glass, acoustic, laminated Glass, windshield shade band Windshield, solar absorbing

Wipers, front intermittent, Rainsense Wiper, rear intermittent with washer

Door handles, body-color

Liftgate, rear manual

**Entertainment**

Audio system, Chevrolet Infotainment 3 system, 8" diagonal HD color touchscreen PM/FM stereo, Bluetooth! audio streaming for 2 active devices, voice command pass-through to phone, Wireless Apple CarPlay and! Wireless Android Auto compatibility (STD)

Audio system feature, 6-speaker system SiriusXM, delete

Infotainment display, 8" diagonal touchscreen

Bluetooth for phone personal cell phone connectivity to vehicle audio system Wireless Apple CarPlay/Wireless Android Auto

Wi-Fi Hotspot capable (Standard with (UE1) OnStar only. Terms and limitations apply. See onstar.com or dealer for details.)

#### Interior

Seats, front 40/20/40 split-bench (Not available with (D07) center floor console and (USR) USB data ports.) (STD)

Seat trim, cloth

Seat adjusters, 8-way power includes 6-way power front passenger seat with 2-way power lumbar Seat adjusters, 10-way power includes 8-way power driver seat with 2-way power lumbar

Seats, second row 60/40 split-folding bench, manual

Seats, third row 60/40 split-folding bench, manual (Not available with (9C1) Police Vehicle or (5W4) Special Service Vehicle.)

Floor covering, Black rubberized vinyl (Deleted when (B30) floor covering is ordered.)

Electronic Precision Shift

Steering column lock, electrical

Steering column, manual tilt and telescopic Steering wheel, urethane

Steering wheel controls, mounted audio, Driver Information Center, cruise control and Forward Collision Alert following gap button (if equipped) (left backside Seek/Scan steering wheel radio buttons are inoperable; these 2 buttons can be repurposed for aftermarket emergency equipment)

Driver Information Center, 4.2" diagonal color display includes driver personalization Rear Seat Reminder

Door locks, power programmable with lockout protection and delayed locking (When ordered with (9C1) Police Vehicle or (5W4) Special Service Vehicle, Auto Lockout is disabled on driver door.)

Keyless Open includes extended range Remote Keyless Entry Cruise control, electronic with set and resume speed

Theft-deterrent system, content, electrical, unauthorized entry

USB data ports, 4 total; 2, one-type-A and one type-C located within center console and 2, one type-A and one type-C located on instrument panel

USB charging-only ports, 4 type-C, (2) located on rear of center console and (2) in 3rd row (1 left and 1 right side below quarter glass side window) (When ordered with (9C1) Police Vehicle or (5W4) Special Service Vehicle, (2) type-C ports are moved to the rear of center seat base and (2) type-C are moved to the cargo area. Deleted when (A50) front bucket seats are ordered.

Window, power with driver Express-Up/Down

Window, power with front passenger Express-Up/Down Windows, power with rear Express-Down

Air conditioning, tri-zone automatic climate control with individual climate settings for driver, right front passenger and rear seat occupants

Air conditioning, rear Defogger, rear-window electric

Power outlets, 2, 120-volt, located on the rear of the center seat and rear cargo area Power outlet, front auxiliary, 12-volt, located in the center stack of instrument panel Mirror, inside rearview manual day/night

Visors, driver and front passenger illuminated vanity mirrors, sliding Assist handles, overhead, driver and front passenger, located in headliner

Assist handles, front passenger A-pillar and second row outboard B-pillar (Deleted when SEO (7X2) left- and right-hand spotlamps or SEO (7X3) left-hand spotlamp are ordered.)

Lighting, interior with dome light, driver- and passenger-side door switch with delayed entry feature, cargo lights, door handle or Remote Keyless Entry-activated illuminated entry and map lights in front and second seat positions. On Police/Special Service vehicles, the control switch is located in the roof console in lieu of the driver - and passenger-side door switch with delayed entry feature. Cargo management system

Chevrolet Connected Access capable (Subject to terms. See onstar.com or dealer for details.)

#### **Safety-Mechanical**

Automatic Emergency Braking Hill Start Assist

StabiliTrak, stability control system with brake assist, includes traction control

#### **Safety-Exterior**

Daytime Running Lamps, reduced intensity low beam

#### **Safety-Interior**

Airbags, Frontal airbags for driver and front outboard passenger; Seat-mounted side-impact airbags for driver and front outboard passenger; Head-curtain airbags for all rows in outboard seating positions (Deleted when (A50) front bucket seats are ordered. Always use seat belts and child restraints. Children are safer when properly secured in a rear seat in the appropriate child restraint. See the Owner's Manual for more information.)



Front outboard Passenger Sensing System for frontal outboard passenger airbag (Always use seat belts and child restraints. Children are safer when properly secured in a rear seat in the appropriate child restraint. See the Owner's Manual for more information.)

OnStar and Chevrolet connected services capable (Terms and limitations apply. See onstar.com or dealer for details.)

Front and Rear Park Assist

Following Distance Indicator (Deleted when (9C1) Police Vehicle or (5W4) Special Service Vehicle is ordered.) HD Rear Vision Camera

Front Pedestrian Braking (Deleted when (9C1) Police Vehicle or (5W4) Special Service Vehicle is ordered.)

Lane Keep Assist with Lane Departure Warning (Deleted when (9C1) Police Vehicle or (5W4) Special Service Vehicle is ordered.)

Forward Collision Alert (Deleted when (9C1) Police Vehicle or (5W4) Special Service Vehicle is ordered.)

Buckle to Drive prevents vehicle from being shifted out of Park until driver seat belt is fastened; times out after 20 seconds and encourages seat belt use, can be turned on and off in Settings or Teen Driver menu (When ordered with (9C1) Police Vehicle or (5W4) Special Service Vehicle, defaulted off. Feature can be turned on in the Infotainment menu.)

Door locks, rear child security, manual

LATCH system (Lower Anchors and Tethers for Children), for child restraint seats lower anchors and top tethers located in all second-row seating positions (Deleted when (ATZ) second row seat delete is ordered.)

Teen Driver a configurable feature that lets you activate customizable vehicle settings associated with a key fob, to help encourage safe driving behavior. It can limit certain available vehicle features, and it prevents certain safety systems from being turned off. An in-vehicle report card gives you information on driving habits and helps you to continue to coach your new driver

Tire Pressure Monitoring System auto learn, includes Tire Fill Alert (does not apply to spare tire) Warning tones headlamp on, driver and right-front passenger seat belt unfasten and turn signal on

3 Years of OnStar Remote Access. The OnStar Remote Access Plan gives you simplified remote control of your properly equipped vehicle and unlocks a variety of great features

in your myChevrolet mobile app. See dealer for details. (Deleted when (UDA) vehicle deactivated communication system is ordered. OnStar Remote Access Plan does not include emergency or security services. Fleet customers will get Fleet Remote Access through OnStar Vehicle Insights. See onstar.com for details and limitations. Available on select Apple and Android devices. Service availability, features and functionality vary by vehicle, device, and the plan you are enrolled in. Terms apply. Device data connection required.)

#### **WARRANTY**

Basic Years: 3

Basic Miles: 36,000

Drivetrain Years: 5

Drivetrain Miles: 60,000

Drivetrain Note: 3.0L & 6.0L Duramax® Turbo-Diesel engines, and certain commercial, government, and qualified fleet vehicles: 5 years/100,000 miles

Corrosion Years (Rust-Through): 6 Corrosion Years: 3

Corrosion Miles/km (Rust-Through): 100,000 Corrosion Miles: 36,000

Roadside Assistance Years: 5 Roadside Assistance Miles: 60,000

Roadside Assistance Note: 3.0L & 6.0L Duramax® Turbo-Diesel engines, and certain commercial, government, and qualified fleet vehicles: 5 years/100,000 miles

Maintenance Note: First Visit: 12 Months/12,000 Miles

**FORD Premium Care 7 Year/125,000 Extended Warranty**

**MODEL**

## Selected Model and Options

CODE	MODEL
CK10706	2024 Chevrolet Tahoe 4WD 4dr Commercial

**COLORS**

CODE	DESCRIPTION
GAZ	Summit White

**SUSPENSION PKG**

CODE	DESCRIPTION
ZW7	Suspension Package, Premium Smooth Ride

**EMISSIONS**

CODE	DESCRIPTION
NE1	Emissions, Connecticut, Delaware, Maine, Maryland, Massachusetts, New Jersey, New York, Oregon, Pennsylvania, Rhode Island, Vermont and Washington state requirements

**ENGINE**

CODE	DESCRIPTION
L84	Engine, 5.3L EcoTec3 V8

**TRANSMISSION**

CODE	DESCRIPTION
MHU	Transmission, 10-speed automatic

**GVWR**

CODE	DESCRIPTION
C6H	GVWR, 7500 lbs. (3402 kg)

READINGTON TOWNSHIP  
REQUEST FOR BIDS: UTILITY/RESPONSE VEHICLE FOR WHITEHOUSE RESCUE  
BID RECEIPT DATE: NOVEMBER 22, 2024- 11:00 AM

---

**AXLE**

CODE	DESCRIPTION
GU5	Rear axle, 3.23 ratio

**PREFERRED EQUIPMENT GROUP**

CODE	DESCRIPTION
1FL	Commercial Preferred Equipment Group

**WHEEL TYPE**

CODE	DESCRIPTION
RD4	Wheels, 20" x 9" (50.8 cm x 22.9 cm) painted aluminum with machine face and Argent Metallic pockets

**TIRES**

CODE	DESCRIPTION
QAE	Tires, 275/60R20SL all-terrain, blackwall

**PAINT**

CODE	DESCRIPTION
GAZ	Summit White

**SEAT TYPE**

CODE	DESCRIPTION
AZ3	Seats, front 40/20/40 split-bench

**SEAT TRIM**

CODE	DESCRIPTION
H1T	Jet Black, Cloth seat trim

READINGTON TOWNSHIP  
REQUEST FOR BIDS: UTILITY/RESPONSE VEHICLE FOR WHITEHOUSE RESCUE  
BID RECEIPT DATE: NOVEMBER 22, 2024- 11:00 AM

---

**ADDITIONAL EQUIPMENT - MECHANICAL**

CODE DESCRIPTION

IOR Audio system, Chevrolet Infotainment 3 system, 8" diagonal HD color touchscreen

CODE DESCRIPTION

5W4 Identifier for Special Service vehicle AMFRemote Keyless Entry Package NHT  
Max Trailering Package

ZL6 Advanced Trailering Package

**ADDITIONAL EQUIPMENT - PACKAGE**

CODE DESCRIPTION

5J9 Calibration, taillamp flasher, Red/White 5LO Calibration, taillamp flasher,  
Red/Red

6J7 Flasher system, headlamp and taillamp, DRL compatible with control wire  
Capless Fuel Fill

JL1 Trailer brake controller, integrated

K3W Battery, 850 cold-cranking amps with 95 amp hour rating

K6K Battery, auxiliary, 760 cold-cranking amps with 70 amp hour rating KX4  
Alternator, 250 amps

NQH Transfer case, active, 2-speed electronic Autotrac RC1 Skid plate, front

READINGTON TOWNSHIP  
REQUEST FOR BIDS: UTILITY/RESPONSE VEHICLE FOR WHITEHOUSE RESCUE  
BID RECEIPT DATE: NOVEMBER 22, 2024- 11:00 AM

---

T66	Wiring provision, for outside mirrors and cargo side mirrors UT7 Ground wires, blunt cut cargo area and blunt cut console area V03 Cooling system, extra capacity
V76	Recovery hooks, 2 front, frame-mounted, Black

**ADDITIONAL EQUIPMENT - EXTERIOR**

CODE DESCRIPTION

Exterior ornamentation delete

RM7 Wheel, full-size spare 17" x 8" (43.2 cm x 20.3 cm) steel V53  
Luggage rack side rails, delete

VK3 License plate front mounting package WUA, Fascia, front high-approach angle

**ADDITIONAL EQUIPMENT - ENTERTAINMENT**

CODE DESCRIPTION

UDA OnStar deactivated (does not delete Bluetooth)

**ADDITIONAL EQUIPMENT - INTERIOR**

CODE DESCRIPTION

5J3 Calibration, Surveillance Mode interior lighting Instrumentation, analog  
Power supply, 100-amp, auxiliary battery, rear electrical center Power supply, 120-amp,  
(4) 30-amp circuit, Primary battery Power supply, 50-amp, power supply, auxiliary battery  
Theft-deterrent system, vehicle, PASS-Key III

ATD Seat delete, third row passenger

READINGTON TOWNSHIP  
REQUEST FOR BIDS: UTILITY/RESPONSE VEHICLE FOR WHITEHOUSE RESCUE  
BID RECEIPT DATE: NOVEMBER 22, 2024- 11:00 AM

---

AX2	Key, unique
BCV	Lock control, driver side auto door lock disable
BTV	Remote start
UN9	Radio Suppression Package, with ground straps
VZ2	Speedometer calibration

**ADDITIONAL EQUIPMENT - SAFETY-INTERIOR**

CODE    DESCRIPTION

Seat belts, 3-point, all seating positions

**ADDITIONAL EQUIPMENT - OTHER**

CODE    DESCRIPTION

Protected idle

VXT    Incomplete vehicle

**SHIP THRU CODES**

CODE DESCRIPTION

VPV    Ship Thru, Produced in Arlington Assembly and shipped to Kerr Industries and onto Arlington Assembly

**FORMS REQUIRING SIGNATURES**



**DISCLOSURE OF OWNERSHIP**  
N.J.S.A. 52:25-24.0 (P.L. 1977 c 33)

Check One

[  ] I certify that the list below contains the names and addresses of all stockholders holding 10% or more of the issues and outstanding stock of the undersigned.

[  ] I certify that no one stockholder owns 10% or more of the issued and outstanding stock of the undersigned

**LEGAL NAME OF APPLICANT:**

---

[  ] Limited Partnership    [  ] Subchapter S Corporation    [  ] Limited Liability Company

[  ] Partnership                      [  ] Corporation (Profit or Non-Profit)                      [  ] Sole Proprietorship

[  ] Limited Liability Partnership                      [  ] Other \_\_\_\_\_

**Complete if the applicant/respondent is one of the three (3) types or corporations;**

Date Incorporated: \_\_\_\_\_                      Where Incorporated: \_\_\_\_\_

**Business Address:**

\_\_\_\_\_  
Street Address    City    State    Zip

\_\_\_\_\_  
Telephone Number    Fax Number

Listed below are the names and addresses of all stockholders, partners or individuals who own ten (10) percent or more of its stock of any classes, or who own ten (10) percent or greater interest therein.  
**(To be completed by for profit only)**

<u>Full Name of Individual</u>	<u>Address of Individual</u>	<u>Share (%) Owned</u>
1. _____	_____	_____
2. _____	_____	_____
3. _____	_____	_____

**Notes:**

1. *Attach additional sheets in this format, if necessary.*
2. *If an organization is shown as a greater than 10% Ownership, attach a similar breakdown of their/ its individual Owners.*

**AFFIDAVIT OF NON-COLLUSION**

The undersigned, being duly sworn according to law, deposes and says:

1. I reside at \_\_\_\_\_  
\_\_\_\_\_
2. The name of the within applicant is \_\_\_\_\_  
\_\_\_\_\_
3. I executed the said bid on behalf of the applicant with full authority to do so.
4. The applicant has not directly or indirectly entered into any agreement, participated in any collusion or otherwise taken any action in restraint of free competitive bid in connection with the contract.
5. All statements contained in the Qualification Statement and Bid and in this Affidavit are true and correct and were made with the full knowledge that Readington Township, County of Hunterdon, its officers and employees, relies upon the truth of the statements therein made in awarding the above-named contract.
6. I further warrant that no person or selling agency has been employed or retained to solicit or service such contract upon an agreement or understanding for a commission, percentage, brokerage or contingent fee, except bonafide employees of or bonafide established commercial selling agencies maintained by the applicant.

Sworn and subscribed to  
before me on this day of

\_\_\_\_\_, 2023

\_\_\_\_\_  
Signature of Applicant

\_\_\_\_\_  
Print Name

\_\_\_\_\_  
Signature of Notary

\_\_\_\_\_  
Print Name

**AFFIRMATIVE ACTION CERTIFICATION**

P.L. 1975, C. 127 (N.J.A.C. 17:27)

If awarded a contract, all procurement and service contractors will be required to comply with the requirements of P.L.1975, C.127, (N.J.A.C. 17:27). Within seven (7) days after receipt of the notification of intent to award the contract or receipt of the contract, whichever is sooner, the contractor should present one of the following to the Purchasing Agent:

1. A photocopy of a valid letter from the U.S. Department of Labor that the contractor has an existing federally-approved or sanctioned Affirmative Action Plan (good for one year from the date of the letter).

OR

2. A photocopy of approved Certificate of Employee Information Report.

OR

3. An Affirmative Action Employee Information Report (Form AA302)

OR

4. All successful construction contractors must submit within three days of the signing of the contract an Initial Project Workforce Report (AA201) for any contract award that meets or exceeds the Public Agency bid threshold (available upon request).

**NO FIRM MAY BE ISSUED A CONTRACT UNLESS IT COMPLIES WITH THE  
AFFIRMATIVE ACTION REGULATIONS OF P.L.1975, C.127.**

---

The following questions must be answered by all bidders:

1. Do you have a federally-approved or sanctioned Affirmative Action Program?

YES \_\_\_\_\_ NO \_\_\_\_\_

If yes, please submit a copy of such approval.

2. Do you have a Certificate of Employee Information Report Approval?

YES \_\_\_\_\_ NO \_\_\_\_\_

If yes, please submit a copy of such certificate.

The undersigned contractor certifies that he is aware of the commitment to comply with the requirements of P.L.1975, c.127 and agrees to furnish the required documentation pursuant to the law.

**Note: A contractor's bid must be rejected as non-responsive if a contractor fails to comply with requirements of P.L. 1975, c.127, within the time frame.**

\_\_\_\_\_  
Applicant's Name

\_\_\_\_\_  
Title

\_\_\_\_\_  
Authorized Signature

\_\_\_\_\_  
Telephone

\_\_\_\_\_  
Print Name

**EXHIBIT A**  
**N.J.S.A. 10:5-31 and N.J.A.C. 17:27**  
**MANDATORY EQUAL EMPLOYMENT OPPORTUNITY LANGUAGE**  
Goods, Professional Services and General Service Contracts  
(Mandatory Affirmative Action Language)

During the performance of this contract, the contractor agrees as follows:

The contractor or subcontractor, where applicable, will not discriminate against any employee or applicant for employment because of age, race, creed, color, national origin, ancestry, marital status, affection or sexual orientation or sex. Except with respect to affection or sexual orientation, the contractor will take affirmative action to ensure that such bidders are recruited and employed, and that employees are treated during employment, without regard to their age, race, creed, color, national origin, ancestry, marital status, affection or sexual orientation or sex. Such action shall include, but not be limited to the following: employment, upgrading, demotion, or transfer; recruitment or recruitment advertising; layoff or termination; rates of pay or other forms of compensation; and selection for training, including apprenticeship. The contractor agrees to post in conspicuous places, available to employees and bidders for employment, notices to be provided by the Public Agency Compliance Officer setting for the provisions of this nondiscrimination clause.

The contractor or subcontractor, where applicable will, in all solicitations or advertisements for employees placed by or on behalf of the contractor, state that all qualified bidders will receive consideration for employment without regard to age, race, creed, color, national origin, ancestry, marital status, affection or sexual orientation or sex.

The contractor or subcontractor, where applicable, will send to each labor union or representative or workers with which it has a collective bargaining agreement or other contract or understanding, a notice, to be provided by the agency contracting officer, advising the labor union or workers' representative of the contractor's commitments under this act and shall post copies of the notice in conspicuous places available to employees and bidders for employment.

The contractor or subcontractor, where applicable, agrees to comply with any regulations promulgated by the Treasurer pursuant to N.J.S.A. 10:5-31 et seq., as amended and supplemented from time to time and the Americans with Disabilities Act.

The contractor or subcontractor agrees to make good faith efforts to employ minority and women workers consistent with the applicable county employment goals established in accordance with N.J.A.C. 17:27-5.2 or a binding determination of the applicable county employment goals determined by the Division, pursuant to N.J.A.C. 17:27-5.2.

The contractor or subcontractor agrees to inform in writing its appropriate recruitment agencies including, but not limited to, employment agencies, placement bureaus, colleges, universities, labor unions, that it does not discriminate on the basis of age, creed, color, national origin, ancestry, marital status, affection or sexual orientation or sex, and that it will discontinue the use of any recruitment agency which engages in direct or indirect discriminatory practices.

The contractor or subcontractor agrees to revise any of its testing procedures, if necessary, to assure that all personnel testing conforms with the principles of job-related testing, as established by the statutes and court decisions of the State of New Jersey and as established by applicable Federal law and applicable Federal court decisions.

READINGTON TOWNSHIP  
REQUEST FOR BIDS: UTILITY/RESPONSE VEHICLE FOR WHITEHOUSE RESCUE  
BID RECEIPT DATE: NOVEMBER 22, 2024- 11:00 AM

---

In conforming with the applicable employment goals, the contractor or subcontractor agrees to review all procedures relating to transfer, upgrading, downgrading and layoff to ensure that all such actions are taken without regard to age, creed, color, national origin, ancestry, marital status, affection or sexual orientation or sex, consistent with the statutes and court decisions of the State of New Jersey, and applicable Federal law and applicable Federal court decisions.

The contractor shall submit to the public agency, after notification of award but prior to execution of a goods and services contract, one of the following three documents:

Letter of Federal Affirmative Action Plan Approval  
Certificate of Employee Information Report  
Employee Information Report Form AA302

The contractor and its subcontractors shall furnish such reports or other documents to the Division of Contract Compliance and EEO as may be requested by the Division from time to time in order to carry out the purposes of these regulations, and public agencies shall furnish such information as may be requested by the Division of Contract Compliance & EEO for conducting a compliance investigation pursuant to Subchapter 10 of the Administrative Code at N.J.A.C. 17:27.

**ACKNOWLEDGEMENT OF RECEIPT OF CHANGES TO  
BID DOCUMENTS FORM**

Pursuant to N.J.S.A. 40A: 11-23.1a, the undersigned hereby acknowledges receipt of the following notices, revisions, or addenda to the bid advertisement, specifications or bid documents. By indicating date of receipt, applicant acknowledges the submitted bid takes into account the provisions of the notice, revision or addendum. Note that the local unit's record of notice to bidders shall take precedence and that failure to include provisions of changes in a bid may be subject for rejection of the bid.

<u>Addendum Number</u>	<u>How Received (mail, fax, pick-up, etc.)</u>	<u>Date Received</u>

**\*\*\*If no addenda has been issued, please write "N/A" above and complete the form below\*\*\***

Company/Applicant: \_\_\_\_\_

By Authorized Representative: \_\_\_\_\_

Signature: \_\_\_\_\_

Printed Name and Title: \_\_\_\_\_

Date: \_\_\_\_\_

**AMERICANS WITH DISABILITIES ACT**

**Equal Opportunity For Individuals With Disabilities**

The Contractor and Readington Township do hereby agree that the provision of Title II of the Americans With Disabilities Act of 1990 (the "ADA") (42 U.S.C. Section 12101 et seq.), which prohibits discrimination on the basis of disability by public entities in all services, programs and activities provided or made available by public entities, and the rules and regulations promulgated pursuant thereto, are made a part of this contract. In providing any aid, benefit or service on behalf of the Township pursuant to this contract, the Contractor agrees that the performance shall be in strict compliance with the ADA. In the event that the Contractor, its agents, servants, employees or subcontractors violate or are alleged to have violated the ADA during the performance of this contract, the Contractor shall defend the Township in any action or administrative proceeding commenced pursuant to this ADA. The Contractor shall indemnify, protect and save harmless the Township, its agents, servants and employees from and against any and all suits, claims, losses, demands or damages of whatever kind or nature arising out of or claimed to arise out of the alleged violation. The Contractor shall, at its own expense, appear, defend and pay any and all charges for legal services and any and all costs and other expenses arising from such action or administrative proceeding or incurred in connection therewith. In any and all complaints brought pursuant to the Township grievance procedure, the Contractor agrees to abide by any decision of the Township which is rendered pursuant to said grievance procedure. If any action or administrative proceeding results in an award of damages against the Township or if the Township incurs any expense to cure a violation of the ADA which has been brought pursuant to its grievance procedure, the Contractor shall satisfy and discharge the same at its own expense.

The Township shall, as soon as practicable after a claim has been made against it, give written notice thereof to the Contractor along with full and complete particulars of the claim. If any action or administrative proceeding is brought against the Township or any of its agents, servants, and employees, the Township shall expeditiously forward or have forwarded to the Contractor every demand, complaint, notice, summons, pleading or other process received by the Township or its representatives.

It is expressly agreed and understood that any approval by the Township of the services provided by the Contractor pursuant to this contract will not relieve the Contractor of the obligation to comply with the ADA and to defend, indemnify, protect, and save harmless the Township pursuant to this paragraph.

It is further agreed and understood that the Township assumes no obligation to indemnify or save harmless the Contractor, its agents, servants, employees and subcontractors for any claim which may arise out of their performance of this agreement. Furthermore, the Contractor expressly understands and agrees that the provisions of this indemnification clause shall in no way limit the Contractor's obligations assumed in this agreement, nor shall they be construed to relieve the Contractor from any liability, nor preclude the Township from taking any other actions available to it under any other provisions of this agreement or otherwise by law.

\_\_\_\_\_  
COMPANY / BIDDER'S NAME

\_\_\_\_\_  
AUTHORIZED SIGNATURE

\_\_\_\_\_  
DATE

\_\_\_\_\_  
NAME (PRINT)                      TITLE

**DISPUTE RESOLUTION**

Any dispute arising under this Contract shall be resolved in accordance with and subject to the limitations contained in N.J.S.A. 40A:11-41.1 as follows:

1. All remedies provided elsewhere in the Contract documents to resolve disputes, claims and protests shall be exhausted. Where the Engineer or Architect is required to issue a decision, such decision shall be a condition precedent to proceeding to resolve the dispute in accordance with paragraph 2.
2. Prior to litigation, the TOWNSHIP and Contractor shall endeavor to settle disputes by mediation in accordance with the current Construction Industry Mediation Rules of the American Arbitration Association. Demand for mediation shall be filed in writing by the party requesting mediation with the other party to this Agreement and with the American Arbitration Association. The Engineer or Architect shall be provided with an information copy of the demand unless the Engineer or Architect is joined. In no event shall such demand be made more than 30 days after completion, acceptance and final payment nor after the date when institution of legal or equitable proceedings regarding the matter in dispute would be barred as a matter of law.
3. Nothing herein shall be construed to prevent the TOWNSHIP and Contractor from agreeing to utilize any other alternative dispute resolution procedure in lieu of or in addition to mediation.
4. Nothing herein shall be construed to prevent the TOWNSHIP from notifying any performance guarantor (Surety) of, and requesting the Surety's assistance in resolving any disputes which involve the Contractor's performance.

Company/Applicant: \_\_\_\_\_

By Authorized Representative: \_\_\_\_\_

Signature: \_\_\_\_\_

Printed Name and Title: \_\_\_\_\_

Date: \_\_\_\_\_



READINGTON TOWNSHIP  
 REQUEST FOR BIDS: UTILITY/RESPONSE VEHICLE FOR WHITEHOUSE RESCUE  
 BID RECEIPT DATE: NOVEMBER 22, 2024- 11:00 AM

**BUSINESS ENTITY DISCLOSURE CERTIFICATION**  
**FOR TRADITIONAL CONTRACTS**  
 Required Pursuant To N.J.S.A. 19:44A-20.8

\_\_\_\_\_  
 (name of firm)

**Part I – Vendor Affirmation**

The undersigned, being authorized and knowledgeable of the circumstances, does hereby certify that \_\_\_\_\_ (name of firm) have not made and will not make any reportable contributions pursuant to N.J.S.A. 19:44A-1 et seq. that, pursuant to P.L. 2004, c. 19 would bar the award of this contract in the one year period preceding January 2, 2023 to any of the following named candidate Committee, joint candidates Committee; or political party Committee representing the elected officials of the Readington Township as defined pursuant to N.J.S.A. 19:44A-3(p), (q) and (r).

John Albanese	Hunterdon County Republicans
Jonathan Heller	Hunterdon County Democrats
Juergen Huelsebusch	Vincent Panico
Adam Mueller	

**Part II – Ownership Disclosure Certification**

I certify that the list below contains the names and home addresses of all Owners holding 10% or more of the issued and outstanding stock of the undersigned.

**Check the box that represents the type of business entity:**

- Partnership     
  Corporation   
  Sole Proprietorship     
  Subchapter S Corporation  
 Limited Partnership   
 Limited Liability Corporation     
 Limited Liability Partnership

Name of Stock or Shareholder	Home Address

READINGTON TOWNSHIP  
REQUEST FOR BIDS: UTILITY/RESPONSE VEHICLE FOR WHITEHOUSE RESCUE  
BID RECEIPT DATE: NOVEMBER 22, 2024- 11:00 AM

---

**Part 3 – Signature and Attestation:**

The undersigned is fully aware that if I have misrepresented in whole or part this affirmation and certification, I and/or the business entity, will be liable for any penalty permitted under law.

Name of Business Entity: \_\_\_\_\_

Signed: \_\_\_\_\_

Title: \_\_\_\_\_

Print Name: \_\_\_\_\_

Date: \_\_\_\_\_

<p>Subscribed and sworn before me this ___ day of _____, 2024.</p> <p>My Commission expires:</p>	<p>_____</p> <p style="text-align: center;">(Affiant)</p> <p>_____</p> <p style="text-align: center;">(Print name &amp; title of affiant) (Corporate Seal)</p>
--	--

**BUSINESS ENTITY DISCLOSURE CERTIFICATION  
FOR NON-FAIR AND OPEN CONTRACTS  
Required Pursuant To N.J.S.A. 19:44A-20.8  
READINGTON TOWNSHIP**

The following is statutory text related to the terms and citations used in the Business Entity Disclosure Certification form.

**“Local Unit Pay-To-Play Law” (P.L. 2004, c.19, as amended by P.L. 2005, c.51)**

**19:44A-20.6 Certain contributions deemed as contributions by business entity.**

5. When a business entity is a natural person, a contribution by that person's spouse or child, residing therewith, shall be deemed to be a contribution by the business entity. When a business entity is other than a natural person, a contribution by any person or other business entity having an interest therein shall be deemed to be a contribution by the business entity.

**19:44A-20.7 Definitions relative to certain campaign contributions.**

6. As used in sections 2 through 12 of this act:

“business entity” means any natural or legal person, business corporation, professional services corporation, limited liability company, partnership, limited partnership, business trust, association or any other legal commercial entity organized under the laws of this State or of any other state or foreign jurisdiction;

“interest” means the TOWNSHIP or control of more than 10% of the profits or assets of a business entity or 10% of the stock in the case of a business entity that is a corporation for profit, as appropriate;

**Temporary and Executing**

12. Nothing contained in this act shall be construed as affecting the eligibility of any business entity to perform a public contract because that entity made a contribution to any Committee during the one-year period immediately preceding the effective date of this act.

~~~~~  
**The New Jersey Campaign Contributions and Expenditures Reporting Act (N.J.S.A. 19:44A-1 et seq.)**

**19:44A-3 Definitions.** In pertinent part...

p. The term "political party Committee" means the State Committee of a political party, as organized pursuant to R.S.19:5-4, any county Committee of a political party, as organized pursuant to R.S.19:5-3, or any municipal Committee of a political party, as organized pursuant to R.S.19:5-2.

q. The term "candidate Committee" means a Committee established pursuant to subsection a. of section 9 of P.L.1973, c.83 (C.19:44A-9) for the purpose of receiving contributions and making expenditures.

r. the term "joint candidates Committee" means a Committee established pursuant to subsection a. of section 9 of P.L.1973, c.83 (C.19:44A-9) by at least two candidates for the same elective public offices in the same election in a legislative district, county, municipality or school district, but not more candidates than the total number of the same elective public offices to be filled in that election, for the purpose of receiving contributions and making expenditures. For the purpose of this subsection: ...; the offices of member of the board of chosen freeholders and county executive shall be deemed to be the same elective

READINGTON TOWNSHIP  
REQUEST FOR BIDS: UTILITY/RESPONSE VEHICLE FOR WHITEHOUSE RESCUE  
BID RECEIPT DATE: NOVEMBER 22, 2024- 11:00 AM

---

public offices in a county; and the offices of mayor and member of the municipal governing body shall be deemed to be the same elective public offices in a municipality.

**19:44A-8 and 16 Contributions, expenditures, reports, requirements.**

*While the provisions of this section are too extensive to reprint here, the following is deemed to be the pertinent part affecting amounts of contributions:*

“The \$300 limit established in this subsection shall remain as stated in this subsection without further adjustment by the commission in the manner prescribed by section 22 of P.L.1993, c.65 (C.19:44A-7.2)

|                                                                                                |                                                 |
|------------------------------------------------------------------------------------------------|-------------------------------------------------|
| Any Political Committees, Candidate Committees, Joint Candidate Committees for or on behalf of | Readington Township Republican Committee        |
| Readington Township Democratic Committee                                                       | Readington Township Republican County Committee |
| Readington Township Democratic County Committee                                                |                                                 |